



# THE GOOD LADY

*Brands that inspire*

2019 Catalogue & Price List



**1800 183 818**  
[WWW.THEGOODLADY.COM.AU](http://WWW.THEGOODLADY.COM.AU)

Premium Commercial Catering  
Equipment from around the Globe

Exclusive Distributor



Since 1952  
Forni e Macchine • Ovens and Machines





THE GOOD LADY



Bringing you premium commercial catering equipment from around the globe."



CONTACT US WHEN YOU NEED THE BEST IN PERFORMANCE



CALL TOLL FREE:  
1800 183 818



ONLINE  
[www.thegoodlady.com.au](http://www.thegoodlady.com.au)



EMAIL  
[sales@thegoodlady.com.au](mailto:sales@thegoodlady.com.au)

**OPERATING HOURS**  
Monday to Friday 9am-5pm

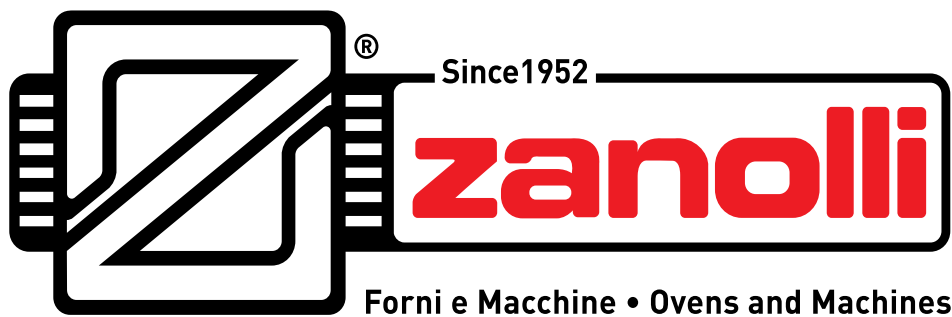

Zanolli products bring together the traditional Italian love of high standards of workmanship and the most advanced technology appreciated by the world's markets. Today, Zanolli is among the most established enterprises in the field.

For over 65 years, Zanolli has devoted itself to the construction of ovens and machinery for pastry, bread and pizza production and is appreciated as an industry leading manufacturer globally.

Zanolli are the original innovators and manufactures of many landmark products that we enjoy and know today around the world.

In 1952 Zanolli produced the first electric pizza oven. The experience and enthusiasm of Giovanni Zanolli combined with the business acumen of his son Gianfranco gave rise to the first in a succession of fine products with a high degree of reliability. This marked the beginning of Zanolli's success in the field of design and production of ovens and machines for pizza, pastry shops and bakeries, rapidly leading to the company's expansion globally.

In 1982 Zanolli submitted an extraordinary patent for the first Italian stackable modular conveyor oven designed to suit the production requirements of its clients.

In 1987 the skillful hands of the Zannoli Synthesis project team put together the first Italian ventilated tunnel oven that continues to be the European market leader for sales and product range. Zanolli continues to be at the forefront of the Italian and European pizza, bread and pastry preparation industry.

Today Zannoli is a household name amongst all pizzeria and bakery establishments around the world.

It is appreciated for its quality, reliability and innovation in design.



*The first ventilated tunnel ovens:  
designed, patented and produced in Italy.*

Made entirely from stainless steel

Double glazed full width inspection door

Easy access for thorough cleaning

Cooling system for contact parts

Omnidirectional wheels with breaks

Conveyor belt with variable speed  
down to a complete halt

Up to working temperature in 20 minutes  
with BRP system (variable power bands)

100 mm high cooking chamber  
Models 08/50 and 12/80 only



Independent power adjustment for top and bottom (Electric models)  
Electronic flame control with min/max adjustment (Gas models)



## CONTROL PANEL

Management of 6 cooking programs. For each program you can set: cooking time, temperature (min/Max for GAS version) and adjustment of power to the top and the bottom of the oven (Electric Version).

ECONOMY function: keeps the oven at a lower temperature if the oven doesn't need to be operated at full working temperature. Save money and energy.

Timer for programmed start. Digital clock, self-diagnostic with display of error message. Backlit display through LCD. Multi-lingual programming.



The maximum temperature of **320°C** is more than sufficient to get perfect results, thanks to the ventilation system.

Fine tuning of the ventilation flow

Reliable components

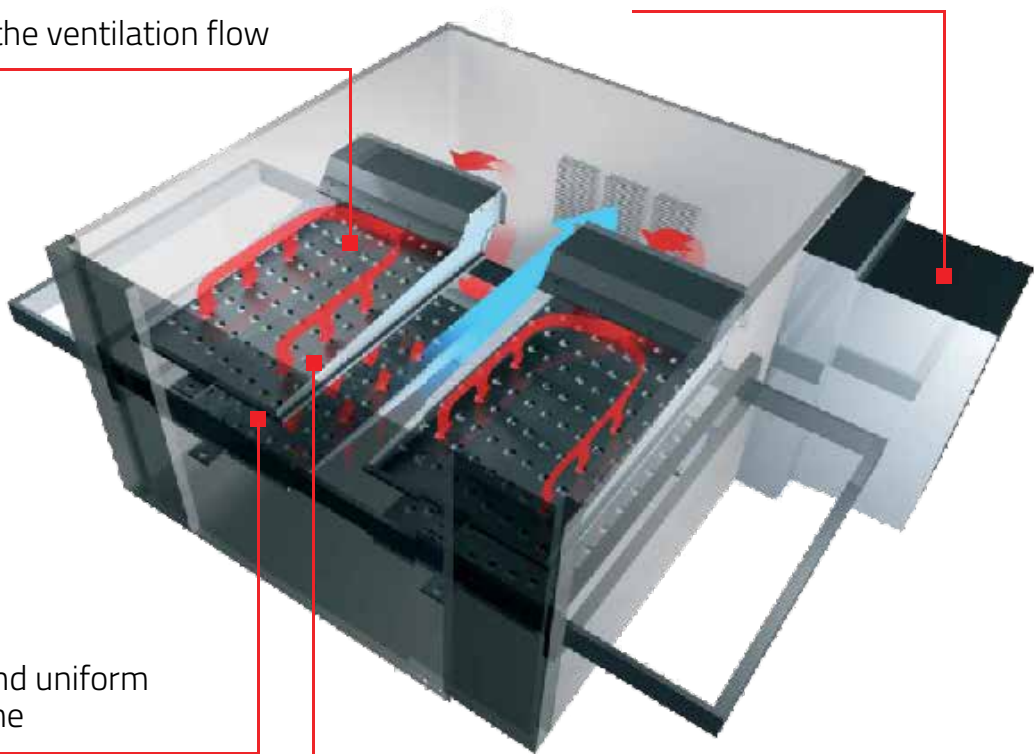

Always even and uniform baking over time

Jets of hot air completely wrap the product as it moves along the wire mesh conveyor giving an evenly cooked result time after time



**All Synthesis ovens are stackable** so you can step up your productivity to meet peak demand.

When you don't need to produce much you can save on energy by using just one baking module.

# SYNTHESIS IMPINGEMENT CONVEYOR OVENS

## SYNTHESIS 08/50 20 inch Gas Conveyor Oven RRP \$22,800 ex GST

**External Dimensions:** 1750mm W x 1260mm D x 490mm H (excl. stand)

**Chamber Dimensions:** 510mm W x 850mm D x 100mm H

**Belt Width:** 20 inches (510mm W)

**Max Temp:** 320°C

**Conveyor Speed:** 1:45 minutes - 30 minutes (or complete halt)

**Front Door Size:** 620mm W x 240mm H

**Weight:** 200 kg

**Natural Gas:** 55 Mj/Hr

**Universal LPG:** 50 Mj/Hr

**Power:** 0.44kw, 10 amp

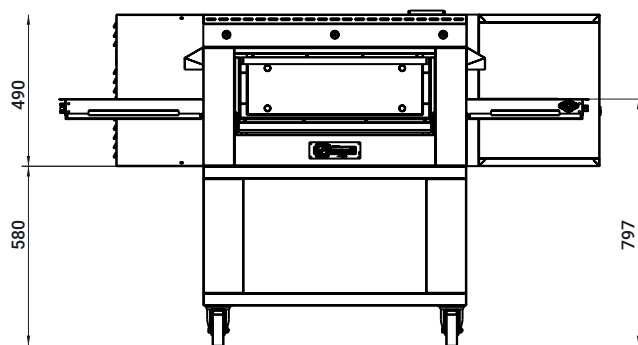
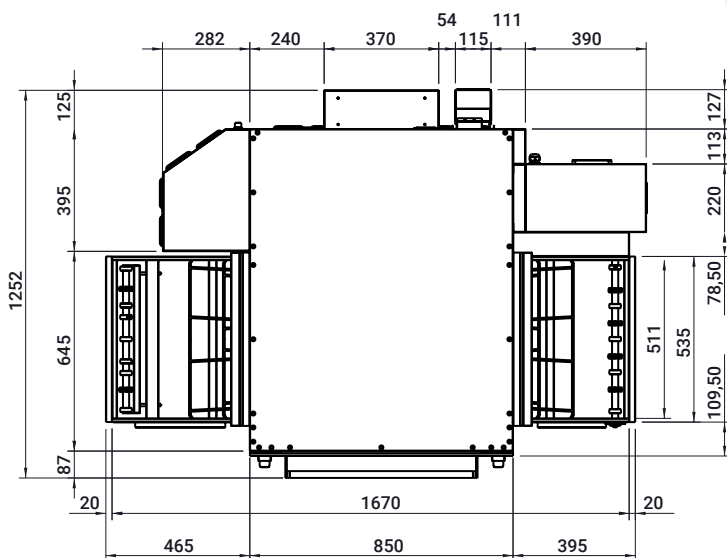

ITALIAN PIZZA* Ø cm	BAKING TIME min.	N° PIZZA / HOUR
20 (145 gr.)	3,5 - 4	135 - 120
25 (230 gr.)	3,5 - 4	90 - 80
30 (330 gr.)	3,5 - 4,5	60 - 50
35 (450 gr.)	3,5 - 4,5	45 - 35
40 (585 gr.)	4 - 5	30 - 25
45 (740 gr.)	4,5 - 5,5	25 - 20

**Note:** The above mentioned information for the output per hour refers to a raw MARGHERITA (thin pizza with tomato and cheese) type, with the weight shown in brackets. This data could change considerably depending on the pizza's mixture and topping.

  
100% made in Italy  
**4 Yr WARRANTY**  
4 YEARS PARTS, 2 YEARS LABOUR





**SYNTHESIS 12/80**  
**32 inch Gas Conveyor Oven**  
**RRP \$32,570 ex GST**

**External Dimensions:** 2180mm W x 1650mm D x 600mm H (excl. stand)

**Chamber Dimensions:** 815mm W x 1200mm D x 100mm H

**Belt Width:** 32 inches (815mm W)

**Max Temp:** 320°C

**Conveyor Speed:** 1:45 minutes - 30 minutes (or complete halt)

**Front Door Size:** 620mm W x 240mm H

**Weight:** 200 kg

**Natural Gas:** 115 Mj/Hr

**Universal LPG:** 100 Mj/Hr

**Power:** 0.44kw, 10 amp

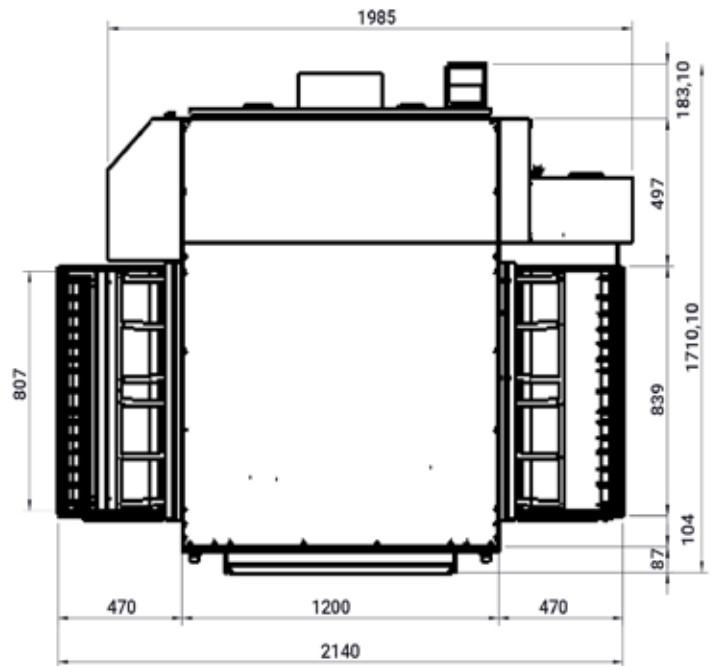
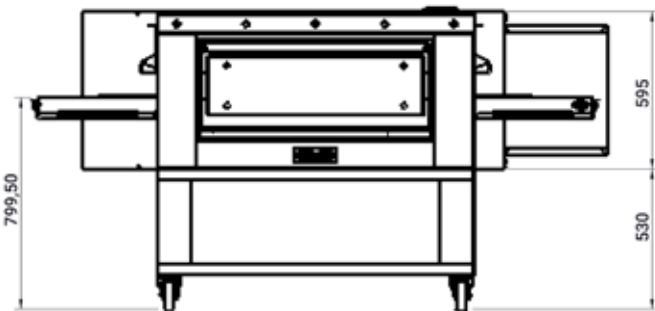

ITALIAN PIZZA* Ø cm	BAKING TIME min.	N° PIZZA/HOUR
25 (230 gr.)	3,5 - 4	220 - 200
30 (330 gr.)	3,5 - 4,5	155 - 120
35 (450 gr.)	3,5 - 4,5	110 - 90
40 (585 gr.)	4 - 5	90 - 70
45 (740 gr.)	4,5 - 5,5	50 - 40
50 (915 gr.)	5 - 6	35 - 30

**Note:** The above mentioned information for the output per hour refers to a raw MARGHERITA (thin pizza with tomato and cheese) type, with the weight shown in brackets. This data could change considerably depending on the pizza's mixture and topping.

100% made in Italy

---

4 Yr WARRANTY

4 YEARS PARTS, 2 YEARS LABOUR

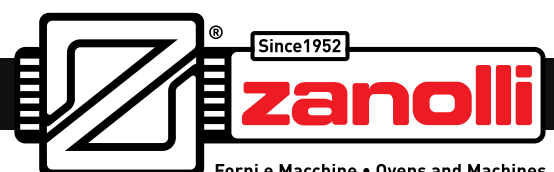

# SYNTHESIS IMPINGEMENT CONVEYOR OVENS



## SYNTHESIS 05/40 16 inch Compact Electric Conveyor Oven RRP \$10,190 ex GST

**External Dimensions:** 1270mm W x 800mm D x 390mm H (excl. stand)

**Chamber Dimensions:** 400mm W x 570mm D x 900mm H

**Belt Width:** 16 inches (400mm W)

**Max Temp:** 320°C

**Conveyor Speed:** 2 minutes - 30 minutes (or complete halt)

**Weight:** 77 kg

**Power Required:** 6.3kw 3 phase

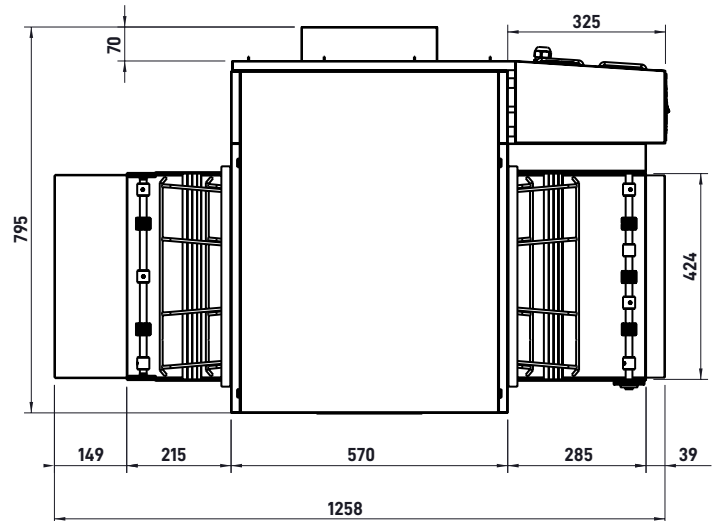
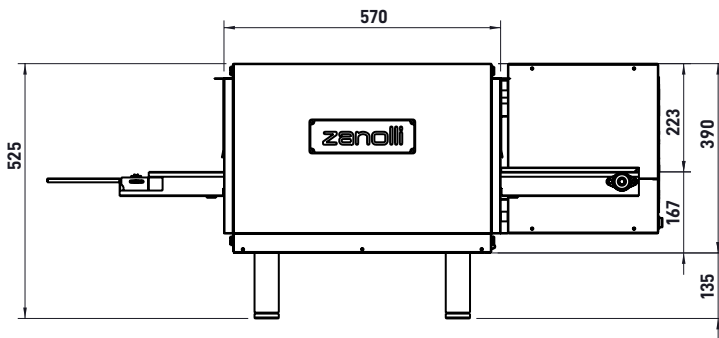

ITALIAN PIZZA* Ø cm	BAKING TIME min.	N° PIZZA / HOUR
15 (80 gr.)	3,5 - 4	130 - 105
20 (145 gr.)	3,5 - 4	70 - 60
25 (230 gr.)	3,5 - 4	39 - 35
30 (330 gr.)	3,5 - 4,5	30 - 25
35 (450 gr.)	3,5 - 4,5	24 - 19
40 (585 gr.)	4 - 5	18 - 15

**Note:** The above mentioned information for the output per hour refers to a raw MARGHERITA (thin pizza with tomato and cheese) type, with the weight shown in brackets. This data could change considerably depending on the pizza's mixture and topping.



100% made in Italy

---

**4 Yr WARRANTY**

**4 YEARS PARTS, 2 YEARS LABOUR**





# ROMEO TUNNEL OVENS

## Romeo 76 Compact Electric Conveyor Toaster w/Glass Window RRP \$3,940 ex GST

**External Dimensions:** 310mm W x  
750mm D x 320mm H

**Chamber Dimensions:** 220mm W x  
500mm D x 100mm H

**Belt Width:** 220mm

**Max Temp:** 310°C

**Conveyor Speed:** 48 seconds -  
12 minutes

**Weight:** 22 kg

**Power Required:** 3kw 15 amp



100% made in Italy

**4 Yr WARRANTY**  
4 YEARS PARTS, 2 YEARS LABOUR

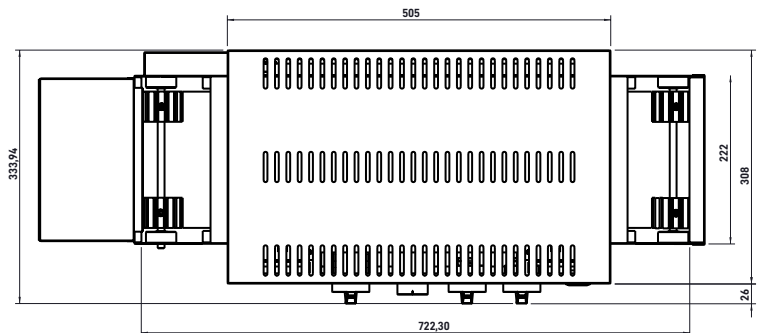
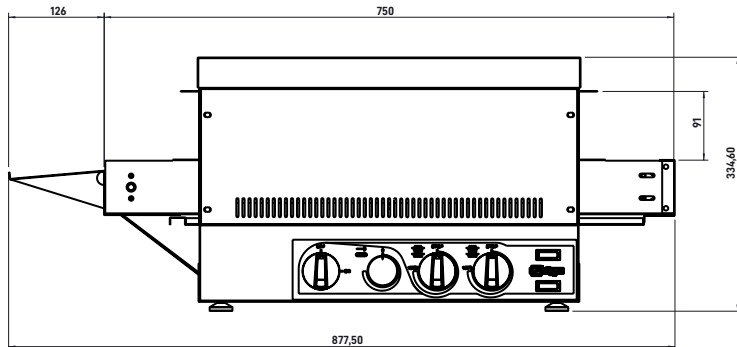

Food warmer (optional)

Glass inspection door  
on the opposite side to  
the control panel (standard)

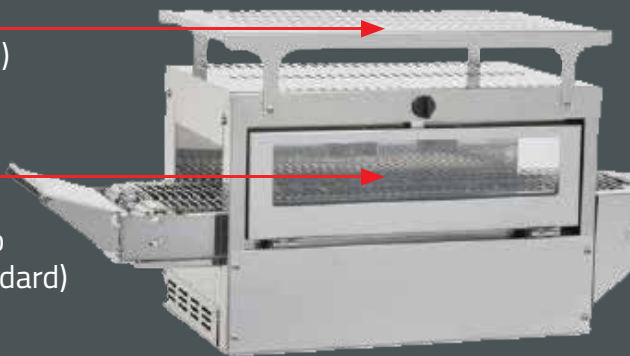

## THE LITTLE OVEN THAT COULD

Romeo is a little electric static tunnel oven suited for cooking frozen products, for toasting bread and warming filled snacks like panini and sandwiches. Aimed above all at sandwich and snack bars, it comes into its own in restaurants and hotels.

Food warmer accessory: \$240 ex. GST

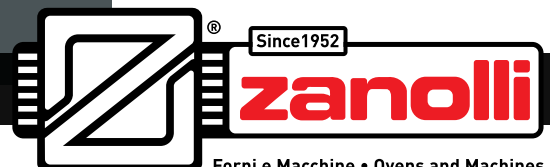

Forni e Macchine • Ovens and Machines



## Terms and Conditions of Sale

### Definitions

1. In these terms and conditions agreement means any agreement or contract entered into for the provision of goods and/or services by The Good Lady to the customer.
2. "The Good Lady" means Catering Wholesalers Pty Ltd T/A The Good Lady of PO Box 342, Botany NSW 2019. The "customer" means any person, firm or corporation requiring goods or services from The Good Lady. "Goods" means goods supplied from The Good Lady to the customer or purchaser. "GST" means the goods and services tax as defined in a New Tax System (Goods & Services Tax) Act 1999 as amended. "Terms" means these terms and Conditions of Sale.

### Basis of Agreement

3. No amendment, alteration, waiver or cancellation of any of these terms is binding on The Good Lady unless confirmed by The Good Lady in writing. The customer acknowledges that no employee or agent of The Good Lady is authorised to make any representation, warranty or promise in relation to the goods sold pursuant to this agreement or these terms of sale, other than as contained in these terms or as confirmed in writing by The Good Lady.
4. Any written quotation provided by The Good Lady to any of its customers concerning the supply of goods and services is:
  - (i) valid for thirty (30) days;
  - (ii) an invitation to treat only;
  - (iii) subject to the customer offering to enter into an agreement in accordance with these terms. Such agreement shall be deemed to be accepted by The Good Lady when The Good Lady confirms its acceptance of such offer in writing or by electronic means or delivers goods to the customer.
5. The Good Lady has no obligation to accept any offer from any customer and may by notice in writing vary or amend these terms at any time, provided that such variation or amendment would only apply to offers accepted by the customer after the date of such notice of variation.
6. All prices quoted in the written quotation or verbally to the customer for the supply of goods include GST and other taxes and duties payable in respect of the goods unless stated otherwise.

### Payment

7. Unless The Good Lady shall otherwise agree, payment for goods and services must be made in full prior to delivery of the goods or provision of any services. Payment by cheques are not made until the payments under the proceeds of the cheques are cleared.
  8. Payment terms may be revoked or amended at the sole discretion of The Good Lady by The Good Lady giving written notice to the customer.
- #### Passing of Property
9. Until the full payment in cleared funds is received by The Good Lady for all goods to be supplied by The Good Lady to the customer as well as any other amount which may be owing to The Good Lady by the customer:

(i) title and property in all goods remains vested in The Good Lady and do not pass to the customer and in the event that goods have been delivered by The Good Lady to the customer and no title to the said goods shall pass to the customer who shall hold the said goods as fiduciary bailee and agent for The Good Lady;

(ii) The Good Lady may without notice enter any premises where it suspects any such goods may be and remove them, notwithstanding that they have been attached to other goods, not the property of The Good Lady and the customer irrevocably licences The Good Lady to enter such premises and indemnifies The Good Lady against all claims, actions, suits and demands brought by any party arising out of such action

### Risk and Insurance

10. Any risk in the goods and any responsibility to cover the goods by insurance in respect of theft, damage or otherwise passes to the customer upon the goods being dispatched from the premises of The Good Lady or from the warehouse of The Good Lady or other place where the goods may be situated and the customer shall assume all risk and liability for loss, damage or injury to persons or to properties of the customer or to third parties arising out of delivery of the goods or their use and possession.

### Acknowledgments by the Customer

11. The customer acknowledges that:

- (i) it has not relied on any advice, recommendation, information or assistance provided The Good Lady or any employee or agent of The Good Lady in relation to the sale of goods and/or services or the use or application of such goods or services;
- (ii) the customer has the sole responsibility to satisfy itself that the goods or services are suitable for the use of the customer or any contemplated use by the customer whether or not such use is known to The Good Lady; and
- (iii) any description of goods provided in a quotation or notice is given by way of identification only and the use of such description does not constitute a contract of sale by description;
- (iv) the customer must provide to The Good Lady particulars of its Australian business number, its order number and the quantity and model number, its delivery address and insurance details when The Good Lady requests it.

(v) once a deposit has been paid, goods may be held for a maximum of 8 weeks only from date of order at the The Good Lady Warehouse. Should any order(s) be required to be held longer by The Good Lady, a 5% charge will be incurred based on the purchase price of the order per week until the goods are ready to be picked up or dispatched.

### Delivery

12. The Good Lady shall provide to the customer the estimated dates of delivery and will use its best endeavours to maintain such estimates, but shall not be liable to the customer in the event that such estimates cannot be maintained.

13. The obligations of The Good Lady as to delivery shall extend to the delivery of goods to the kerbside or street level only. In the event that there are additional delivery requirements the customer shall notify The Good Lady at a reasonable time prior to any such delivery and any additional costs thereby incurred shall be to the customer's expense.

## Inspection and Return of Goods

14. Unless the customer has inspected the goods and given written notice to The Good Lady within two (2) business days of delivery that the goods do not comply with the relevant specifications or descriptions, the goods shall be deemed to have been accepted in good order and condition and no claim for credit, non-delivery or repair of goods shall be accepted unless notification is made within two (2) days in writing to The Good Lady.

15. In the event that The Good Lady otherwise accepts the return of goods for credit, such credit will endure for a maximum of twelve (12) months from the date of first sale to the customer of the returned goods and any such return will be liable to a re-stocking fee being not less than 25% of the invoice value of the goods.

16. In the event that The Good Lady accepts the return of goods for credit, the customer remains liable for the costs of re-delivering the goods to the manufacturer and shall be liable to pay The Good Lady such costs.

17. Nothing in these terms shall oblige The Good Lady to accept returns of goods for credit if such goods were damaged during their assembly or installation and nothing shall oblige The Good Lady to pay any of the costs of assembly or installation or make it responsible for any losses arising from defective assembly or installation and nothing in this clause shall affect the construction of Clause 19 of these terms.

## Cancellation of Orders

18. No order may be cancelled, modified or deferred without the prior written consent of The Good Lady and if The Good Lady shall consent to any cancellation, modification or deferral the customer shall reimburse it for all losses including loss of profits and shall be liable to pay a cancellation and re-stocking fee being not less than 25% of the invoice value of the goods.

## The limitation of liability of The Good Lady

19. Nothing in these terms and conditions shall affect or shall be deemed to affect any right, entitlement or other remedy conferred upon the customer by the provisions of the Trade Practices Act 1974 or other State or Territory Legislation as amended and nothing in these terms shall be interpreted as excluding, restricting or having the effect of excluding, restricting or modifying the application of any of the Trade Practices Act or any State or Territory legislation applicable to the sale of goods or the supply of services which cannot be excluded, restricted or modified provided that The Good Lady liability under any aforesaid provisions is limited, at its option to:

(i) replacement or repair of the goods or the supply of equivalent goods or payment of the costs of replacing or repairing the goods or requiring equivalent goods; or

(ii) refund of the purchase price;

and The Good Lady will not be liable in any case for any consequential or other direct or indirect loss or damage arising by breach of these terms.

## Warranties

20. Subject to these terms:

(i) The Good Lady at its discretion may repair or replace any goods to remedy any failure due to faulty workmanship or materials, provided that such goods may have acceptable variance (as determined by The Good Lady).

(ii) The Good Lady is not obliged to repair or replace goods or remedy any failure due to faulty workmanship or materials unless the customer

supplies it with detailed information on the warranty form provided by The Good Lady as to the defects in the goods. The Good Lady is not liable for any collateral damage caused to the customer for any collateral damage accruing to the customer for any faulty work or materials supplied;

(iii) the customer acknowledges that any warranty given in respect of plant and equipment is the warranty of the manufacturer of the goods and that The Good Lady is not responsible for such warranties and gives no warranty of its own in respect of the said goods;

(iv) the customer acknowledges the provisions of any Act or law, (including but not limited to the Trade Practices Act 1974) implying terms and conditions and warranties or any other terms and conditions of warranties which might otherwise apply to or arise out of the agreement between The Good Lady and the customer in relation to the goods, are hereby expressly negated and excluded to the full extent permitted by law;

(v) the customer further acknowledges that the benefit of this warranty is subject to the customer not being in breach of these terms and conditions or of any additional agreement which is in place;

(vi) The Good Lady, or its representatives, being given access to the goods for the purpose of inspection and rectification of any claim;

(vii) the customer not having repaired or undertaken to repair the goods without the prior authorisation of The Good Lady nor altering the goods in any way;

(viii) the customer having used and maintained the goods in accordance with the manufacturer's recommendations, their failure not being the result of incorrect or poor maintenance by the customer;

(ix) the customer acknowledging that it has not relied upon any advice given by The Good Lady, its agents, servants, representatives or employees in relation to the suitability for any purposes of the goods

## Miscellaneous

21. This agreement shall be construed in accordance with the laws of the State of New South Wales and the parties agree to the non-exclusive jurisdiction of the Courts of the State of New South Wales and of Courts entitled to hear appeals from these Courts.

22. Failure by The Good Lady to enforce any of these terms shall not be construed as a waiver of any of The Good Lady rights.

23. If any of the terms of this agreement shall be unenforceable such terms shall be read down so as to make it enforceable or if it cannot be read down the condition shall be severed from these terms without affecting the enforceability of the remaining terms and conditions.

24. Any notices given by either party to this agreement may be delivered personally or sent by facsimile or pre-paid mail to the last known address of the addressee and shall be deemed to be received upon posting or receipt of facsimile transmission or email.

## Waiver and Assignment

25. No failure by The Good Lady to insist on strict performance of any of any terms in these terms is a waiver of any right or remedy which The Good Lady may have and is not a waiver of any subsequent breach or default by the customer.

26. Neither the agreement nor any rights arising under the agreement may be assigned by the customer without the prior written consent of The Good Lady which it may give or refuse at its absolute discretion.



 @thegoodladyau

 Facebook.com/TheGoodLady

 @TheGoodLadyAU

 The Good Lady

 linkedin.com/company/the-good-lady

**Distributor**



**THE GOOD LADY**  
*Brands that inspire*

1800 183 818 | [WWW.THEGOODLADY.COM.AU](http://WWW.THEGOODLADY.COM.AU)